

Creating a Ratiometric Current Excitation in Sensors Using the MAX1464 Signal Conditioner

The MAX1464 can be easily configured to generate constant current excitation for sensors that is ratiometric to the power supply voltage for resistive transducer applications. Applications utilizing sensing elements with high temperature coefficients, TCR, such as piezo resistive bridges, RTDs, etc. are typically implemented with constant current excitation. This application note suggests a simple resistive network that can be implemented to provide a ratiometric current source for sensor excitation.

Applications using sensing elements with high temperature coefficients, TCR, such as piezo resistive bridges, RTDs, etc. are typically implemented with constant current excitation. The MAX1464 can be easily configured to generate constant current, ratiometric to the supply voltage, for resistive transducer applications. This application note suggests a simple resistive network to provide the ratiometric current source. To reduce external components, the uncommitted op-amps internal to the MAX1464 can be used.

The MAX1464 is a highly integrated programmable sensor signal conditioner with two input/output channels and 16-bit resolution and provides for signal amplification, calibration, linearization, and temperature compensation. The MAX1464 supports a choice of analog or digital outputs including 4-20 mA, ratiometric 0.5 to 4.5V, and PWM.

Many of today's sensor applications use sensing elements, such as piezo-resistive sensors, that have very high temperature coefficient of resistance (TCR), and sensitivity (TCS). These two coefficients are typically of comparable values, but opposite signs. To minimize the overall temperature dependency and improve performance of the sensing elements, the sensing element is normally driven with constant current. The MAX1464 can be configured to generate a constant current for these applications. Figure 1 shows a simple resistive circuit that generates the constant current I_B for excitation of the sensing element R_B . The equations that apply to the circuit in Figure 1 are given below. Figure 2 shows the resulting ratiometric current for V_{DD} ranging from 4.5V to 5.5V.

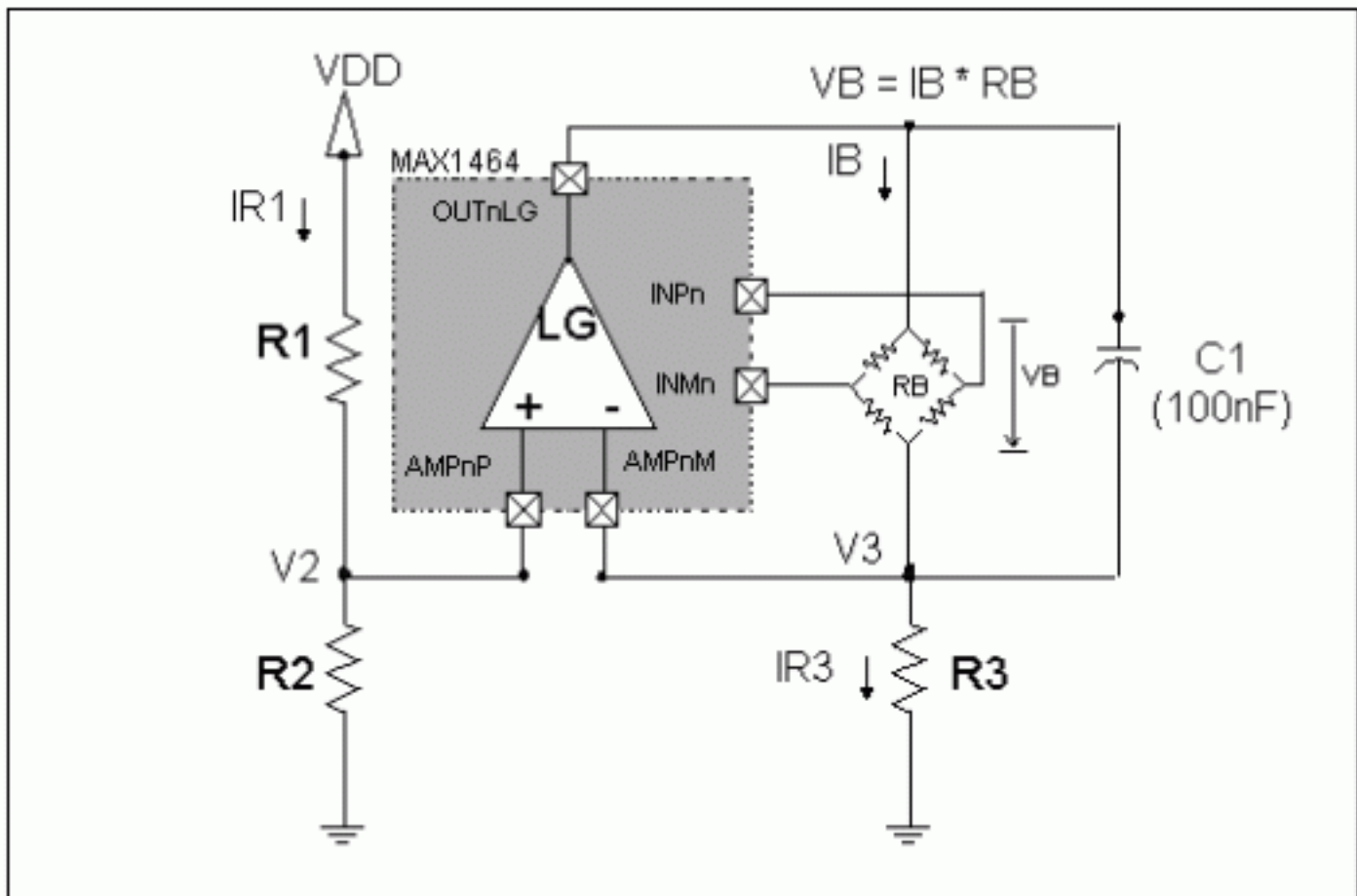

Figure 1: Constant current source circuit for the MAX1464 applications

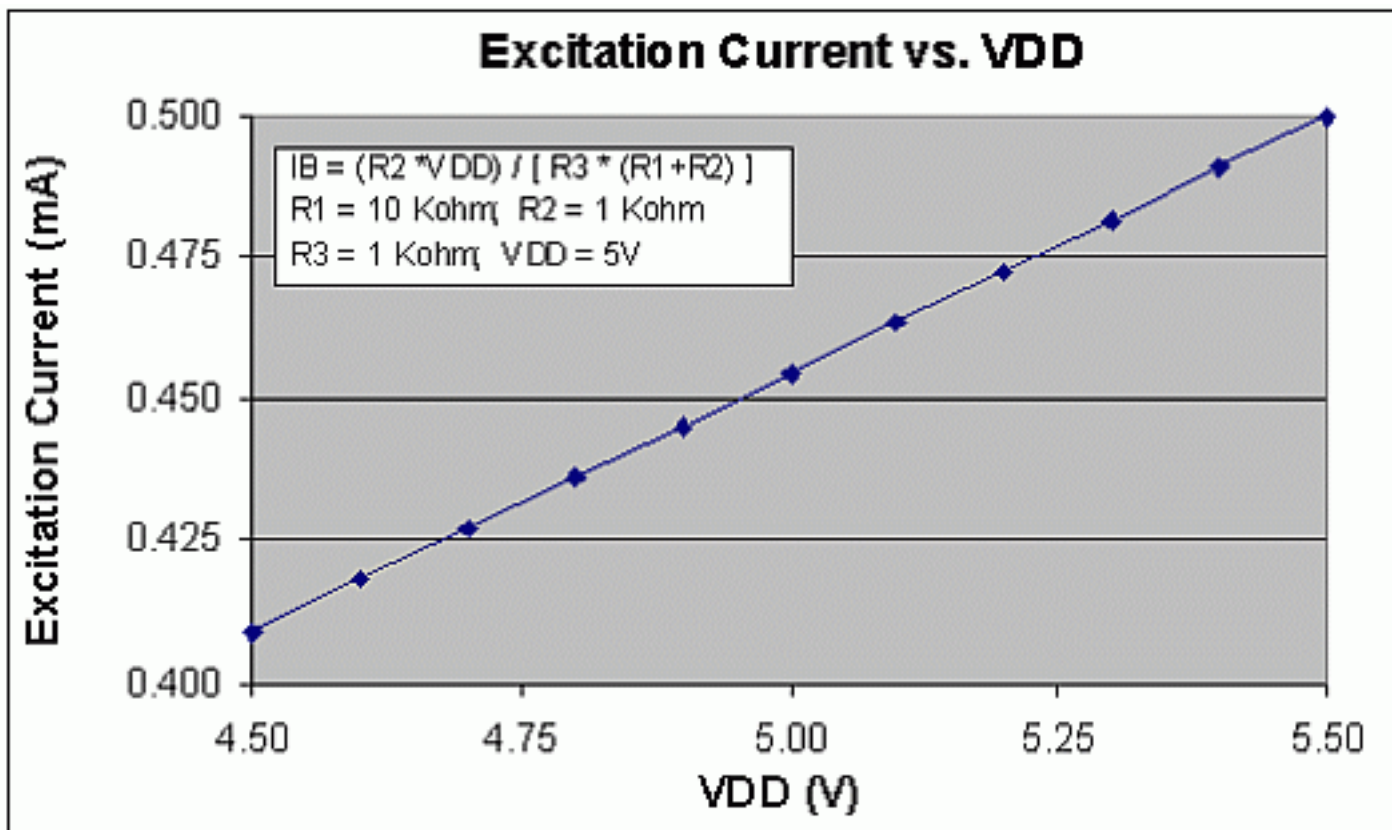

Figure 2: Excitation current is ratiometric to VDD

Values of resistors R1 and R2 in Figure 1 must be selected such that the current (IR1) drawn from the VDD line will not overload the power supply or does not compromise the sourcing capability of the VDD line to supply the MAX1464 signal conditioner.

The current IR3, through the resistor R3, is equal to V3/R3 and the only source for this current is the op_amp LG. Hence, IB = IR3. Since the voltage V2 is proportional to the ration of R1 and R2 resistors, as long as R1 and R2 have identical TCRs, the voltage V2 (and hence V3, V2=V3) will be independent of the environment temperature. However, the current IR3 will change with temperature due to TCR of R3. Since IB = IR3, the voltage VB will also be affected by TCR of R3. To minimize the effect of R3 on temperature performance of the sensor, a resistor with smallest TCR possible must be used. Additionally, VB will also change with temperature due to TCR of the transducer's input impedance. A typical piezo-resistive transducer has TCR of about 3000 PPM that accounts for the bulk of the change in VB over temperature. In a typical application of the MAX1464, this will not be an issue since all temperature errors will be lumped together and will be corrected by the compensation algorithm.

Equations:

$$IB = IR3 \quad (1)$$
$$VB = IB * RB \quad (2)$$

Where RB is the transducer's input impedance

$$IR3 = V3 / R3 \quad (3)$$
$$V3 = V2 = VDD * R2 / (R2 + R1) \quad (4)$$
$$IR1 = VDD / (R1 + R2) \quad (5)$$

When selecting the application parameters, select the excitation current, IB, such that (VB+V3)<VDD over all temperature conditions. The capacitor C1, in Figure 1, is added to filter out noise on the sensor's excitation signal. In applications where the signal noise is within the acceptable limits, C1 is not necessary.

Example:

The following component values will generate 0.455mA current for sensor excitation when VDD=5V and remains ratiometric to the VDD as the VDD ranges from 4.5V to 5.5V:

$$R1 = 10.0 \text{ Kohm}; R2 = 1.0 \text{ Kohm}; R3 = 1.0 \text{ Kohm}$$

Applying these values to the equations gives V2 = 0.455V and V3 = 0.455V. Equations 3 and 1 show the bridge current to be IB = 0.455mA. Equation 5 shows the VDD supply is not excessively loaded with IR1 = 0.455mA. Also, for a transducer with bridge impedance of 5Kohm, a bridge voltage of VB = 2.27V will be generated.

In sensor applications where the transducer and the signal conditioner are at different

temperatures, the transducer bridge voltage V_B can be connected to one of the MAX1464 input channels and be utilized as the sensor temperature indicator provided that the TCR of the resistor R3 is known or negligible.

In the suggested circuit below, LG represents the internal 'Large' op-amp of either one of the MAX1464 output channels. In real applications, the unused 'Large' or 'Small' internal op-amps of either output channels or an external op-amp can be used.

References:

MAX1464 Datasheet